

Oticon ♦ Delta

906 69 310 00 / 10.06 Printed in Denmark



INSTRUCTIONS FOR USE



Congratulations

You have chosen to take action and improve your ability to communicate.

This booklet contains the information you need to get the full benefit of your new hearing devices.

Daily use is straightforward and you should be able to get started right away.

We hope you will enjoy your new Delta devices.

Content

Description	4
On/off	6
Product case	8
Putting on the device	10
Daily maintenance – Domes	12
Changing the dome	14
Daily maintenance – Micro Moulds	16
Changing batteries	22
Daily use and care	24
Trouble shooting for devices with domes	26
Trouble shooting for devices with Micro Moulds	28
International warranty	30
Warnings	Yellow pages

The device consists of:

- A triangular amplifier unit, which holds the microphones and the battery. The amplifier unit sits comfortably and discreetly behind the ear.
- A speaker unit where a thin tube connects the speaker with the amplifier. The speaker sits in the ear canal and delivers sound directly into the ear.
- An optional ear grip, which follows the contour of the ear and ensures that the speaker and the whole device is securely fastened.
- An ear piece, a dome (A) or a custom made Micro Mould (B), which holds the speaker comfortably in the ear. It also protects the speaker against ear wax.

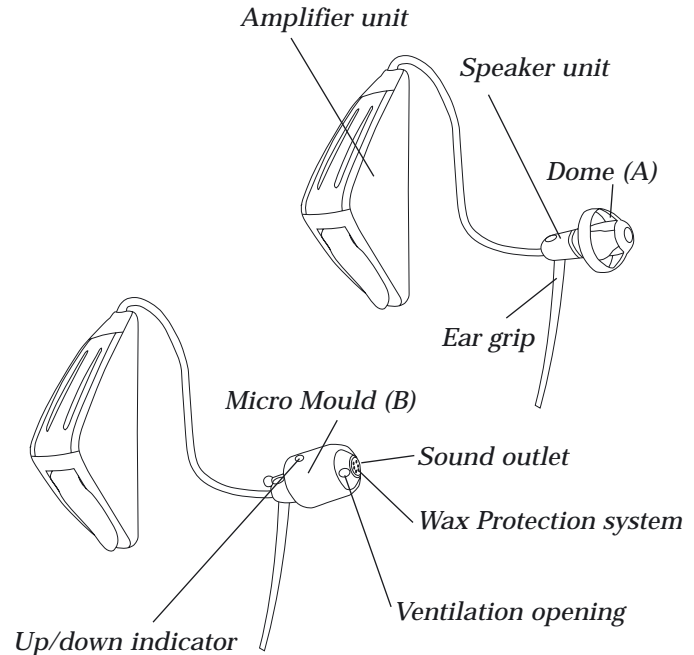

On/off

Close the battery door to turn on the device. You will hear a short series of beeps and a jingle, which indicates that the device is turned on.

Open the battery door to turn it off. When you are not using the device, please make sure it is turned off and that the battery door is fully open.

We recommend you use the product case supplied with your hearing devices when storing them for the night.

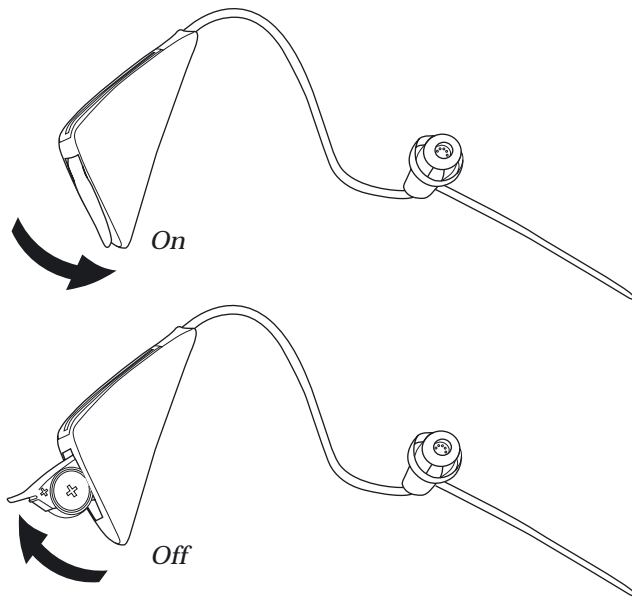

Product case

When you are not using your devices, place them in the product case. Ensure that the battery doors are open, when you place the devices in the case.

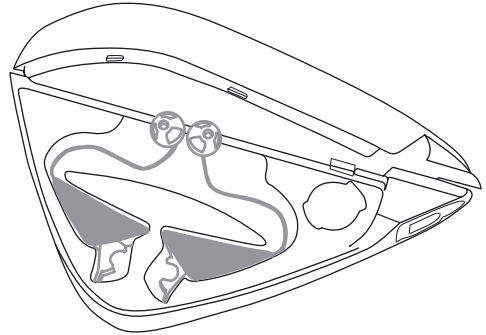

Putting on the devices

Turn the device on. Place the speaker, with the ear piece attached, into your ear first and then place the amplifier behind your ear. If the instrument comes with a Micro Mould, make sure that the coloured dot (blue or red) on the mould is facing towards the amplifier unit (upwards) to ensure a correct position in the ear canal.

Make sure that the ear piece is placed so that the tube follows the contour of the skin.
If the instrument has an ear grip, place it in the concha as indicated in drawing 4.
Alternatively place the amplifier behind your ear.
Put the speaker into your ear canal.

Left/right indication for hearing devices
Blue colour indicates left device.
Red colour indicates right device.

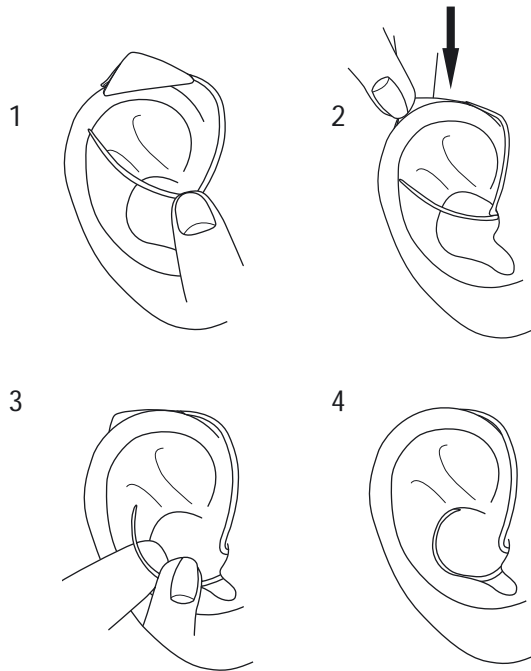

Daily maintenance – Domes

Clean the speaker unit daily. Use a dry cloth and rub off any earwax.

The dome should not be cleaned. When you require a fresh, clean dome, remove the existing one and put on a fresh one.

We recommend the dome to be replaced at least once a month or as directed by your Hearing Care Professional.

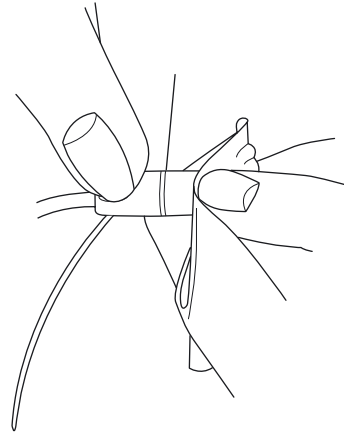

Changing the dome

The dome is easy to replace. Replace it whenever needed. Use a fingernail and hold the bottom of the dome. Then pull it off. Place the new dome on the speaker and ensure that it is fastened securely. Throw out the old dome.

Under the dome you will notice a white wax filter attached to the end of the speaker. This is a wax filter that will keep debris from damaging the speaker. If this filter becomes clogged, contact your Hearing Care Professional for service and replacement of the filter.

Note: The dome is made of a soft, medically approved rubber material. If the dome comes off in the ear canal, it will not cause any harm. If you can – carefully take it out. Maybe let another person help you. Do not push the dome into the ear canal. If you have any doubts, contact your Hearing Care Professional.

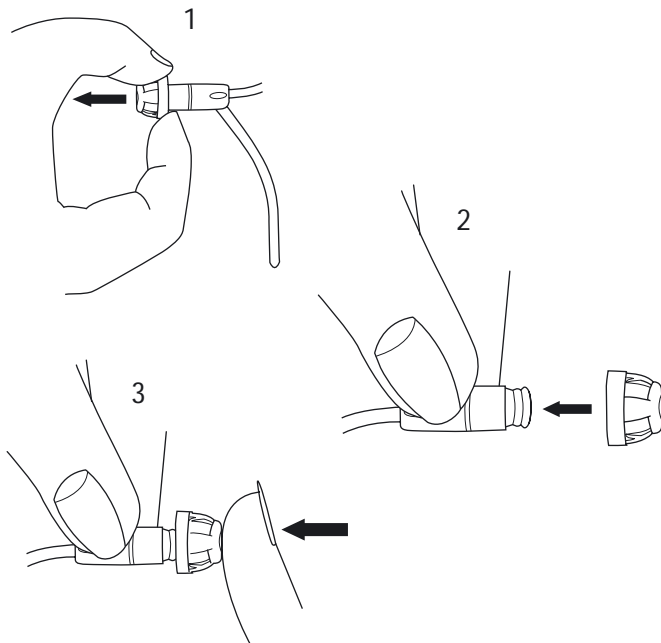

Daily maintenance – Micro Moulds

Clean the speaker unit and Micro Moulds daily.
Use a dry cloth and rub off any ear wax.

Note. The hearing devices and the Micro Moulds must never be washed.

Your ear canal produces ear wax (cerumen) which may clog up the sound outlet or the ventilation opening. Therefore your hearing devices contain filters to prevent wax accumulation.

Clean away any traces of wax from around the ventilation opening. Use the special cleaning tool provided by your Hearing Care Professional.

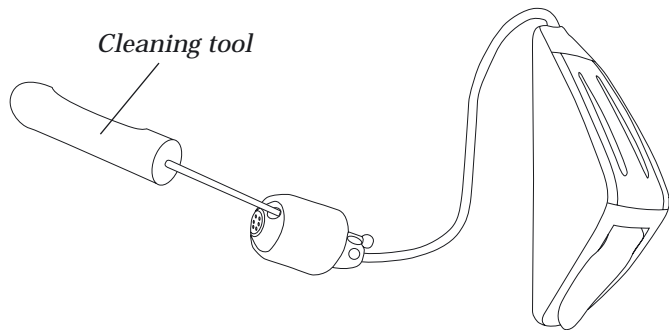

Replace the wax protection system

1. Remove the tool from the shell. The tool has two ends, one with the new filter (A) and one with the removal tool (B).
2. Insert the removal tool into the sound outlet of the Micro Mould.
3. Pull the used wax filter out slowly keeping the tool straight.
4. Turn the tool 180°.
5. Push the new filter into the sound outlet and gently remove the tool.
6. Throw out the used tool. Do not reuse.

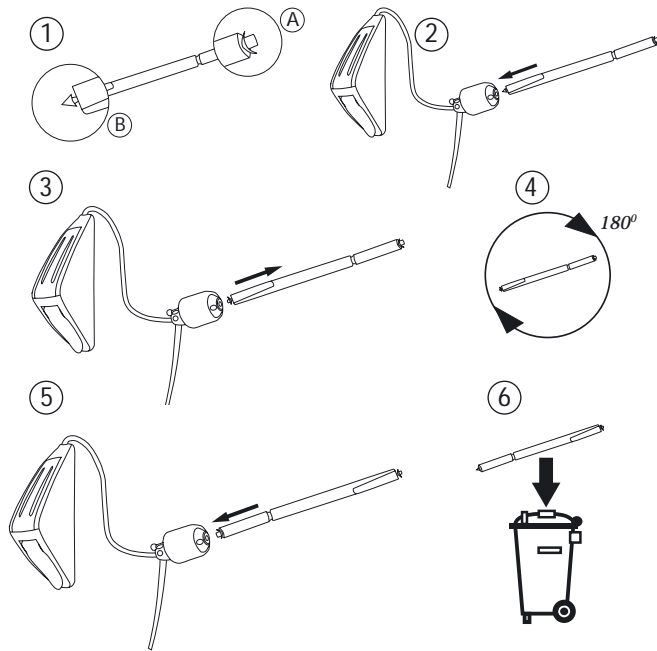

The wax filter should be changed:

- When you can see that the filter placed in the Micro Mould is clogged,

or

- When the hearing device does not sound normal.
(If this is the case, please check the filter in the Micro Mould to see if it is clogged.)

DO NOT USE OTHER WAX PROTECTION SYSTEMS ON THE DEVICES.

Changing batteries

When the battery is low, you will hear a short series of beeps. Remove the sticky label from a fresh battery. Insert the new battery with the +marking facing the +marking on the battery door. Close the battery door. It will take a few seconds before the battery works to full capacity.

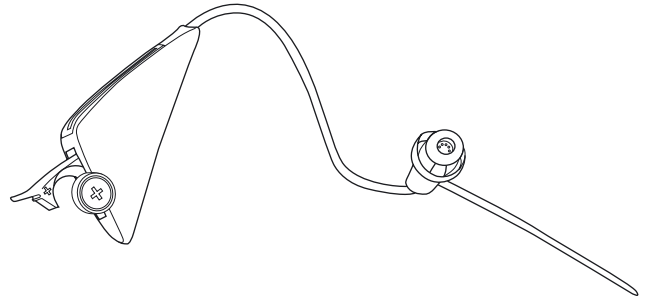

Daily use and care

The devices are designed to deliver improved understanding, especially in noisy surroundings.

We do recommend that you wear them all day. In the beginning, you will hear new sounds that you have not heard for a while. You quickly get used to your devices, and in quiet surroundings, they should not be uncomfortable or loud.

In group situations, try to focus on the person you want to hear. Position yourself in front of the person you want to communicate with. If you miss a word, ask the person to repeat it.

Using the telephone

If your instruments have domes, you may place the receiver directly over your ear canal to let the sound from the phone enter directly into your ear.

If you are using devices with Micro Moulds you should tilt the receiver edge lightly on your cheekbone in order to let the sound flow directly into the hearing device's microphone opening.

Even though your new devices are designed to comply with the strictest "Standards of International Electromagnetic Compatibility", not all mobile phones are fully compatible and might introduce some interference.

Avoid heat, humidity and chemicals. Your devices should not be exposed to extreme heat, e.g. left inside a car parked in the sun. They should not be worn in the shower, during swimming or in heavy rain. And they should not be dried in a microwave or normal oven. Please be aware that chemicals used in cosmetics, hair spray, perfume, after shave and suntan lotion, etc. may damage your devices.

Trouble shooting for devices with domes

The dome is blocked with earwax

Replace the dome

There's no sound

Change batteries

Replace the dome

The dome is stuck in your ear canal

Gently remove it – avoid pushing it further in
Alternatively contact your Hearing Care Professional

Dirty or corroded battery

Clean battery surfaces and drawer with dry cloth or change battery

Sound is disappearing and hearing device beeps

Change batteries

There's no sound and I have changed the dome and battery

Contact your Hearing Care Professional

If none of the above solutions solves the problem, ask your Hearing Care Professional for assistance.

Trouble shooting for devices with Micro Moulds

The Micro Moulds are blocked with earwax

Replace the wax protection system

There's no sound

Change batteries

Replace the wax protection system

The Micro Mould is stuck in your ear canal

Gently remove it - avoid pushing it further in
Alternatively contact your Hearing Care Professional

Dirty or corroded battery

Clean battery surfaces and drawer with dry cloth or
change battery

Sound is disappearing and hearing device beeps

Change batteries

There's no sound and I have cleaned the Micro
Mould, changed the wax protection system and
battery

Contact your Hearing Care Professional

If none of the above solutions solves the problem,
ask your Hearing Care Professional for assistance.

International Warranty

Oticon hearing devices are covered by a limited warranty issued by the manufacturer for a period of 12 months from the date of delivery. This limited warranty covers manufacturing and material defects in the hearing device itself, but not accessories such as batteries, tubing, earwax filters, etc.

Problems arising from improper handling or care, excessive use, accidents, repairs made by an unauthorized party, exposure to corrosive conditions, physical changes in your ear, damage due to foreign objects entering the device, or incorrect adjustments are NOT covered by the limited warranty and may void it.

The above warranty does not affect any legal rights that you might have under applicable national legislation governing sale of consumer goods. Your Hearing Care Professional may have issued a warranty that goes beyond the clauses of this limited warranty. Please consult him/her for further information.

If you need service

Take your hearing device to your Hearing Care Professional, who may well be able to sort out minor problems and adjustments on the spot.

Oticon Warranty Certificate

Name of Owner: _____

Dispenser: _____

Dispenser Address: _____

Dispenser Phone: _____

Purchase Date: _____

Warranty Period: _____ Month: _____

Model Left: _____ Serial no.: _____

Model Right: _____ Serial no.: _____

Battery Size: _____

*Oticon A/S
9, Kongebakken
DK-2765 Smørum*

CE 0543

www.hear-it.org
www.oticon.com



Waste from electronic equipment
must be handled according to
local regulations.

906 69 310 00 / 10.06 Printed in Denmark

Warnings

You should familiarize yourself fully with the following general warnings and the entire contents of this booklet before using your hearing devices.

Hearing devices can be dangerous if used improperly. Such actions can result in severe injury, permanent hearing loss, or can even be fatal.

Hearing devices and batteries can be dangerous if swallowed

- Hearing devices, their parts, and batteries are not toys and should be kept out of reach of children and anyone who might swallow these items or otherwise cause injury to themselves.
- Never change the battery or adjust the controls of the hearing devices in front of infants, small children or people with learning difficulties.

- Discard batteries carefully in a place where infants, small children or people with learning difficulties cannot reach them.
- Batteries have occasionally been mistaken for pills. Therefore carefully check your medicine before swallowing any pills.
- Never put your hearing devices or batteries in your mouth for any reason, as they are slippery and could be swallowed by accident.
- Some Oticon hearing devices can be supplied with a tamper-resistant battery compartment upon request. This is strongly recommended for infants, small children, and people with learning difficulties.
- If a battery or hearing device is swallowed, see a doctor immediately.

Use the device as instructed by your Hearing Care Professional

- Hearing devices should be used only as directed and adjusted by your Hearing Care Professional. Misuse could result in sudden and permanent hearing loss.
- Never allow others to wear your hearing instruments as incorrect/wrongful usage could cause permanent damage to their hearing.

Battery use

- Always use batteries recommended by your Hearing Care Professional. Batteries of low quality may leak and cause bodily harm.
- Never attempt to recharge your batteries. They may explode and cause serious injury.
- Never dispose of batteries by burning them. There is a risk that they will explode and cause serious injury.

Dysfunction in hearing devices

- Hearing devices may stop functioning, for instance if the batteries have expired or if the receiver/loud-speaker is blocked by moisture or earwax. You should be aware of this possibility, in particular when you are in traffic or otherwise dependent on warning sounds.

Interference

- Your hearing devices have been thoroughly tested for interference, according to the most stringent international standards. But new technical developments constantly bring new products into society, and some may emit electromagnetic radiation, leading to unforeseen interference in hearing devices. Examples include induction cooking appliances, shop alarm systems, mobile telephones, fax machines, personal computer devices, X-rays, Computer tomography, etc.

Possible side effects

- Hearing devices may cause an accelerated accumulation of cerumen (earwax).
- The otherwise non-allergenic materials used in hearing devices may in rare cases cause a skin irritation.

Consult a doctor if you experience any of these side effects.

Wax protection system

- Always visually inspect your hearing devices to ensure that there is no gap between the wax protection flange and the tip of the Micro Mould.

If you are in any doubt about the use or replacement of your wax protection system, contact your Hearing Care Professional.